

Installation Instructions

STEP 1 - CHECK MEASURE

Measure window to ensure correct size blind has been selected for installation type (face or recess mount).

Ball chain mechanism can be easily changed to left or right side by simply pulling out and swapping chain mechanism with pin end.

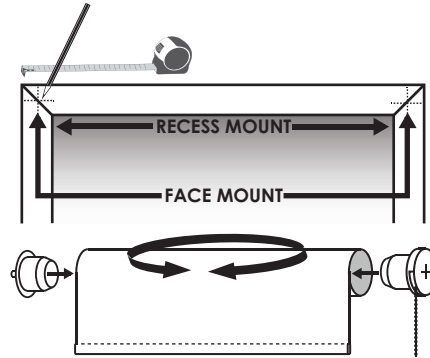

STEP 2 - BRACKET POSITION

Universal brackets allow for either face or recess mount installation.

Measure & mark bracket positions, including fixing point locations.

Pre-drill pilot holes for screws to prevent any splitting of timber or architrave.

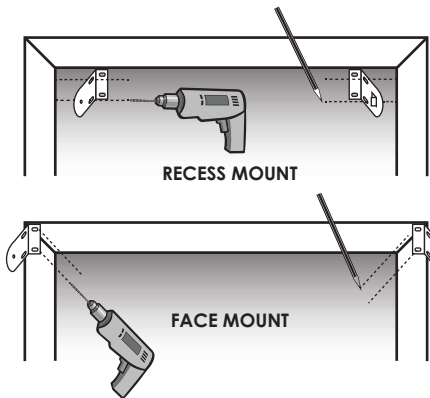

STEP 3 - FIX BRACKETS

Secure brackets to wall or architrave using screws provided.

Ensure brackets are on correct side & correspond to the chain mechanism/pin on the blind.

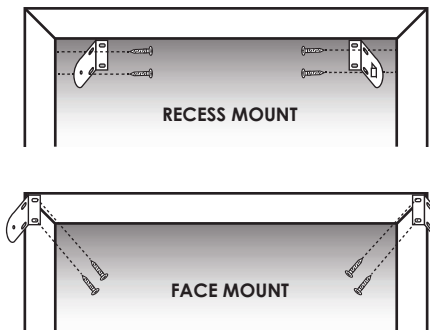

STEP 4 - INSTALL BLIND

Once brackets are secured, lift blind into place, inserting the chain mechanism side into brackets first.

For larger size blinds, two person lift may be required.

Gently side pin into second bracket & secure in place.

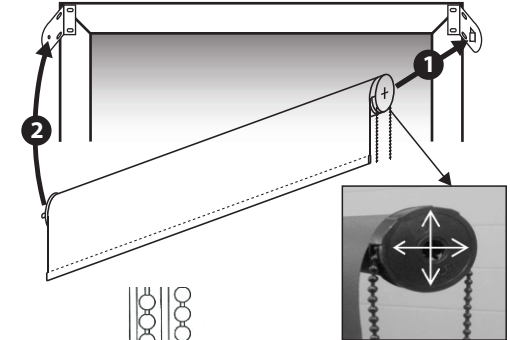

STEP 5 - SAFETY TENSION DEVICE

1. Pass cord and or chain through the bottom of the device.
2. Insert screw.
3. Pull down with light tension.
4. Screw into place.

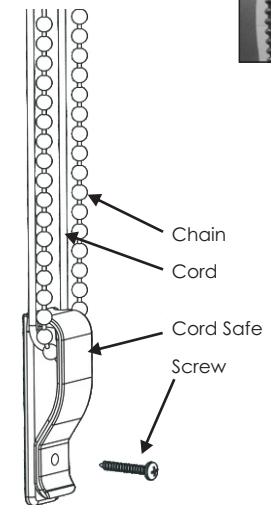

WARNING

To avoid creating a possible strangulation hazard for children, the corded internal window covering must be installed in such a way that a loose cord cannot form a loop 220mm or longer at a height of less than 1600mm above floor level.

A cord guide may be installed lower than 1600mm above the floor level if the cord is sufficiently secured or tensioned to prevent a loop 220mm or longer from being formed.

If a cord guide is installed lower than 1600mm above floor level it must be designed to prevent a child from being able to remove the cord.

If a cleat is used to secure the cord it must be at least 1600mm above floor level because a child is capable of unwinding a cord from a cleat.